



GREAT MAGTECH(XIAMEN)
ELECTRIC CO., LTD.



Tel: 86-592-6682467 Fax: 86-592-6682467
Email: pcmagnet@greatmagtech.com
www.precastconcretemagnet.com

**FORMWORK
MAGNET**

CONTENTS

FORMWORK MAGNET INTRODUCTION	01
GENERAL SPECIFICATIONS	02-03
FORMWORK PRODUCTION TECHNIQUE	04
FORMWORK MATERIAL AND TREATMENT PROCESS	05-06
PRODUCTION EQUIPMENT	06-08
PAST PROJECT	08
PAST PRODUCT LIST	09
PRODUCT DRAWING	09
PACKAGING	10
ON SITE APPLICATION	10



COMPANY PROFILE

Founded in 2000, Great Magtech (Xiamen) Electric Co., Ltd.(GME) is a brand dedicated to offer a wide range of pre-cast concrete products and construction components, We have successfully cooperated World Top 500 Companies, like Lafargeholcim. Our shutter magnets are now sold to all over the world, especially Middle East, Northern Europe, Southeast Asia and Oceania.

Our factory is in Ningbo, covering an area of 50000 square meters. The investment has reached RMB 170 million successively since its establishment. There are more than 200 professional and

experienced staff, including 45+ R&D experts. Products already passed TS16949, ISO9001-2000, CE, RoHS and SGS guidelines.

Be in the light of the principle of "the quality and service first", the company built up a strict quality management system, such as APQP, FMEA, SPC, PPAP, MSA. We prides itself in delivering products and services that consistently take the business forward and provide clients with new, exciting innovations to meet the ever increasing demand for quality and value for money.

FORMWORK MAGNET INTRODUCTION

With the rapid development of the prefabricated construction industry, magnetic fixed products such as shuttering magnet and ferrule insert magnet magnet have been fully applied in the production of precast concrete components. The magnetic block is directly embedded in the formwork, so it is more convenient, more efficient and more stable than the magnetic box.



Through the adhesive force of the magnetic block, the formwork is in close contact with the template, so that the formed formwork system is fixed. The formwork system that needs to be formed is thus fixed. Since the steel formwork and the magnetic blocks are integrated, no positional movement occurs and the formwork system is not deformed. At the same time, the simple and quick operation of the magnets makes the whole work safer and more stable. With the matching pry bar, the formwork magnet can be picked up and the steel formwork can be easily removed from the template. Since the magnets are located inside the steel formwork groove, concrete residue or other dirt does not cause damage to the entire formwork system.



GENERAL SPECIFICATIONS

The precast concrete formwork magnet consists of a steel formwork and embedded magnets. The product is custom-made in size, and many types for selection: with slotting, without chamfer, one chamfer, or two chamfers.



NO CHAMFER

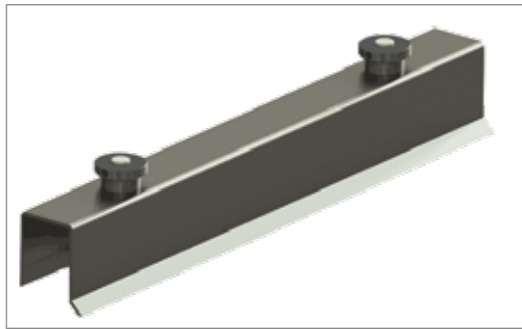

ONE CHAMFER



TWO CHAMFER

	Formwork Length	Magnet Block Quantity
Formwork Height < 100mm	1m	2x450kg
	2m	2x900kg
	3m	3x900kg
	3.5m	3x900kg
Formwork Height < 100mm	1m	2x1600/1800/2100kg
	2m	2x1600/1800/2100kg
	3m	3x1600/1800/2100kg

FORMWORK PRODUCTION TECHNIQUE

Folding (used to produce formwork magnet of 1-2m)

It is integrally formed by a folding machine, with double groove chamfering, single groove chamfering and no chamfering.

Welding (used to produce formwork magnet of 2-3m)

Hand soldering equipment, suitable for the production of formwork magnet with heights over 100mm.



FORMWORK MATERIAL AND TREATMENT PROCESS

Q235A Carbon Steel, Blackening Treatment

Q235A carbon steel is generally used, which has better magnetic flux than stainless steel and low cost. The anti-rust treatment of the iron shell is usually blackening. It is a common method of chemical surface treatment. The principle is to produce an oxide film on the metal surface to isolate the air and achieve the purpose of anti-rust.



Q235A Carbon Steel, Polished Treatment

Some customers are concerned that the oxide layer on the exterior will have an effect on the cement surface, so polished treatment is adopted



Aluminum Alloy

The aluminum alloy formwork magnet is composed of an aluminum alloy formwork and embedded magnet blocks. Due to the special processing technology, the aluminum alloy formwork has high strength, and the deformation rate is small compared to the formwork of steel or stainless steel. Product consistency and stability. The weight of the formwork is greatly reduced, which is conducive to production operations.

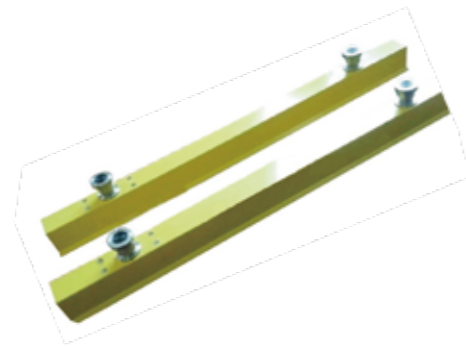

Stainless Steel

The stainless steel formwork magnet is composed of a stainless steel formwork and an embedded magnet blocks, which is light in weight and convenient for the operation of the mechanical arm.



PRODUCTION EQUIPMENT

What sets us apart from our competitors are our ideal magnetic solution, excellent quality, and great service.

With testing laboratory which equipped with the state-of-the-art measuring and testing devices, our QC dept. ensures ongoing development and maintenance of high quality standards and guarantees full compliance with customer requirements and all applicable regulations. (production equipment and process as below)

1 Case Processing (laser cutting bed from Europe, precision-oriented.)



2 Case Processing (laser cutting bed from Europe, precision-oriented.)



3 Welding Treatment (European Brand & High Accuracy)

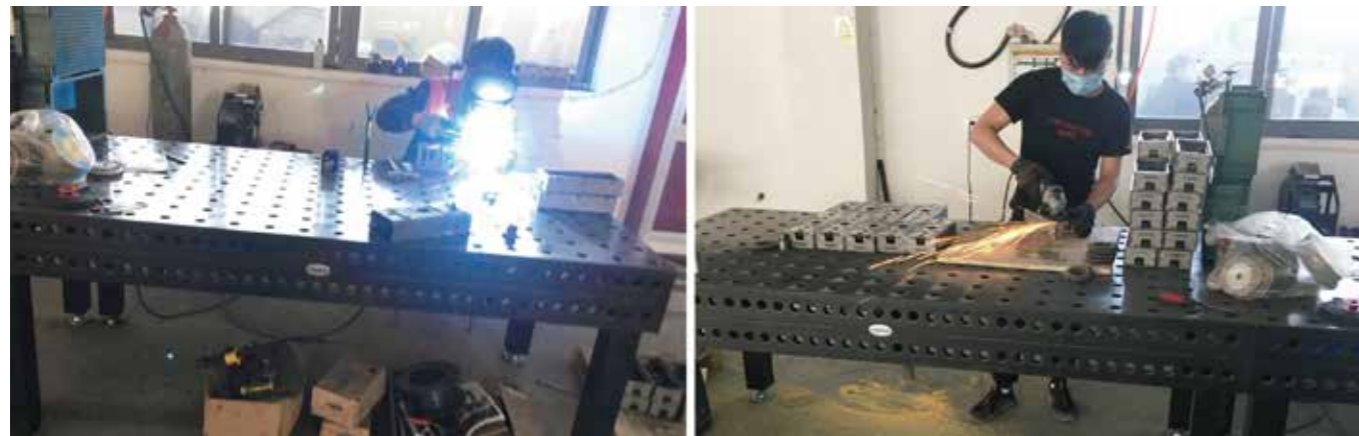

4 Inside Magnetic Core Treatment



5 Head Button Processing (CNC Lathe Machining)



6 Complete Production



From the production of parts to the final product, the side mold requires 6-7 steps. (The specific production process depends on different equipment capabilities)
To assure the quality, we would conduct strict quality check in accordance with the industry standard. A special quality inspector is responsible for inspecting each process.

PAST PROJECT

With the rise of prefabricated buildings on a global scale, our products also play a non-negligible role in certain projects. Just this year, our side shutter technology combined with our customers' construction techniques in the Philippines and Thai customers, making contribution to the local prefabricated building infrastructure. (below shows the product list for the Philippines project)

PAST PRODUCT LIST

SHUTTERING WITH MAGNETS	Coating	Material	QTY
120H*120W*3000L-3 MAGNETS(1800KGS)	Blackening	Stainless steel	76
120H*120W*2000L-2 MAGNETS(1800KGS)	Blackening	Stainless steel	96
120H*120W*1000L-2MAGNETS(1800KGS)	Blackening	Stainless steel	50
100H*120W3000L-3 MAGNETS(900KGS)	Blackening	Stainless steel	20
100H*120W*2000L-2 MAGNETS(900KGS)	Blackening	Stainless steel	20
100H*120W*100L-2MAGNETS(900KGS)	Blackening	Stainless steel	15
70H*70W*3000L-3 MAGNETS(900KGS)	Blackening	Stainless steel	128
70H*70W*2000L-2 MAGNETS(900KGS)	Blackening	Stainless steel	96
70H*70W*1000L-2 MAGNETS(900KGS)	Blackening	Stainless steel	30
Total			531

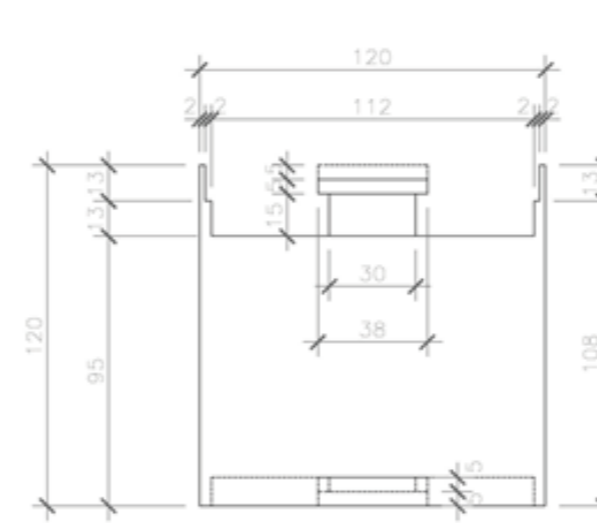

Shuttering Section Details(120mm)

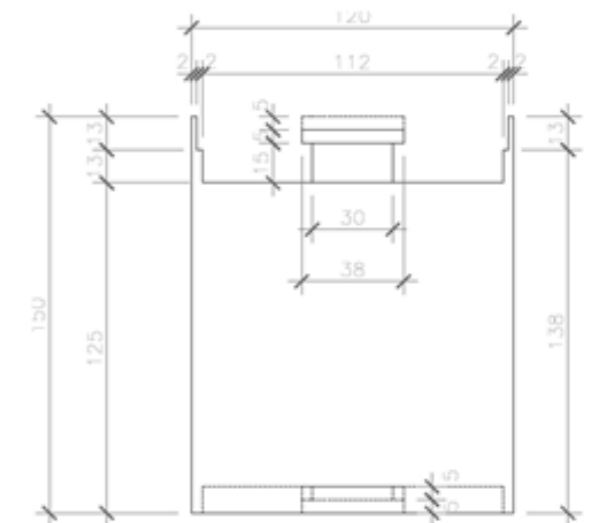

Shuttering Section Details(150mm)

PRODUCT DRAWING

We have a professional engineer team to be our backup. For every order, we would carefully design and provide our solution according to our customer's need.

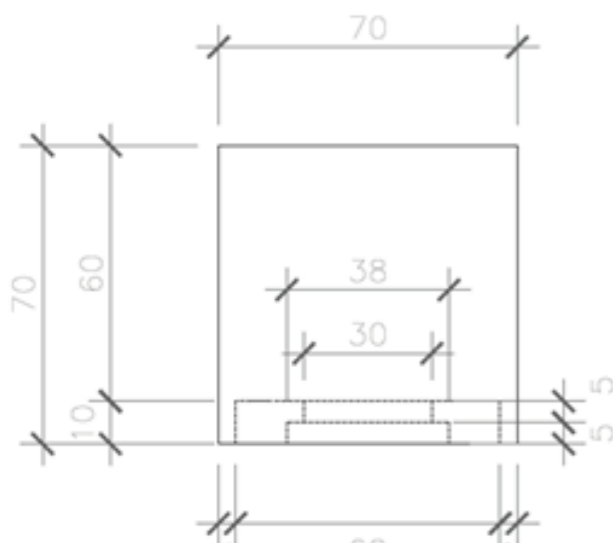

Shuttering Section Details(70mm)

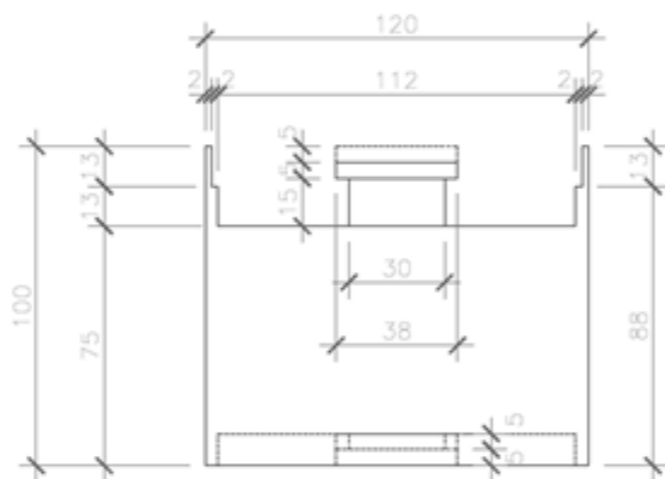

Shuttering Section Details(70mm)

PACKAGING



ON SITE APPLICATION

